

Article number: 2307033321

Description: E+G Two-spoke handwheel
VRTP.250-GXX2-A20+I

Measures

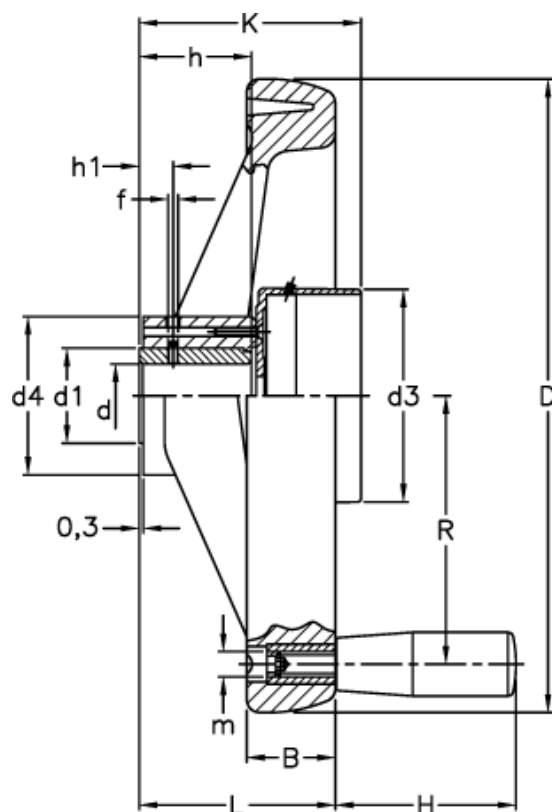

B	= 32	h	= 38
D	= 250	h1	= 12
d1	= 35	K	= 74
d3	= 76	L	= 70
d4	= 58	m	= M10
d H7	= 20	R	= 105
f	= M8		
H	= 90		